

LOCAL HEAT TRANSFER BETWEEN A MOVING SAND HEAP AND ANNULAR FINS

V. A. Kalender'yan, V. V. Kornaraki,
and T. M. Batishcheva

UDC 536.24:541.182.3

It is shown here how the heat transfer intensity distributes over the surface of annular fins cooled by a transversely moving heap of dense loose material. The heat conduction through the fins is analyzed and the fin efficiency is corrected to account for the radial nonuniformity of the heat transfer distribution.

According to [1], the use of annular finning on a tubular surface cooled in a transverse stream makes it possible to intensify the heat transfer and to enhance the per unit heat dissipation. A general relation is given in [1] for calculating the mean heat transfer intensity. For the thermal design of finned heat exchangers, however, one must know the efficiency of such fins. Inasmuch as a transverse cooling of a cylindrical surface by a dense heap of material is characterized by a considerable nonuniformity, one should expect some degree of nonuniformity also at the fin surfaces and a resulting nonuniform heat transfer along a fin. As has been shown in [2, 3, 4] and elsewhere, the latter circumstance must be taken into consideration when the fin efficiency E is calculated. In connection with this, the authors have studied the local heat transfer in an air-tight dense heap of loose material around a cylinder with annular fins. The method of investigation was based on steady-state thermal conditions and the test apparatus was as shown earlier in [1, 2]. The electrical calorimeter for the experiment (Fig. 1a) consisted of a wooden cylinder 33.5 mm in diameter with a wooden fin 30 mm high pressed around it. The cylinder with the fin was equipped with nichrome heater elements made up of 0.2×5 mm ribbons connected in series. The ribbons were mounted horizontally across (Fig. 1a), because maximum nonuniformity of the heat transfer and the temperature field could be expected in the direction of the material flow. The cylinder and fin heater elements producing a uniform thermal flux density were energized from the ac power line through transformers and a voltage stabilizer, with a K-50 instrument panel and a control voltmeter (the error in power measurements did not exceed 2-3%). Under the ribbons, as shown in Fig. 1a, were placed the hot junctions of copper-constantan thermocouples connected through a switch with the common cold junction to an R 2/1 potentiometer. The local heat transfer coefficients at the fin and cylinder surface were calculated from the mean thermal flux and the local temperature drops. In order to determine the effect of fin spacing, also unheated dummy fins were pressed on the cylinder. The loose material was an air dried mixture of quartz sand with the average grain size 0.52 mm. The tests were performed at sand stream velocities varying from 1.2 to 11.0 mm/sec. At each velocity the measurements were made with the cylinder in five different positions shown in Fig. 1b and rotated through 45, 90, 135, and 180°. The results yielded a precise distribution pattern of heat transfer intensity over the fin and the base cylinder surfaces. It is noteworthy that the results for each fixed point did not depend on the position of the ribbons (along or across the flow), since the heat overrun along the ribbons was small. The distribution curve of the heat transfer coefficient along a fin at different velocities of the sand heap (1.2, 4.56, and 11.0 mm/sec) has been plotted in Fig. 1b from the thermocouple readings at the tip and at the base of a fin.

Over the entire fin surface the heat transfer intensity is lower at the base than at the tip. However, the rate at which the heat transfer coefficient varies along the radius is different: it is high at the front ($0^\circ < \varphi < 40^\circ$), reaching its maximum at $\varphi \cong 45^\circ$, then it decreases to its minimum within the $90^\circ < \varphi < 135^\circ$ region and again increases. When the sand heap moves at 4.56 mm/sec, for example, the ratio of heat

M. V. Lomonosov Technical Institute, Odessa. Translated from *Inzhenerno-Fizicheskii Zhurnal*, Vol. 20, No. 6, pp. 1066-1071, June, 1971. Original article submitted June 15, 1970.

© 1973 Consultants Bureau, a division of Plenum Publishing Corporation, 227 West 17th Street, New York, N. Y. 10011. All rights reserved. This article cannot be reproduced for any purpose whatsoever without permission of the publisher. A copy of this article is available from the publisher for \$15.00.

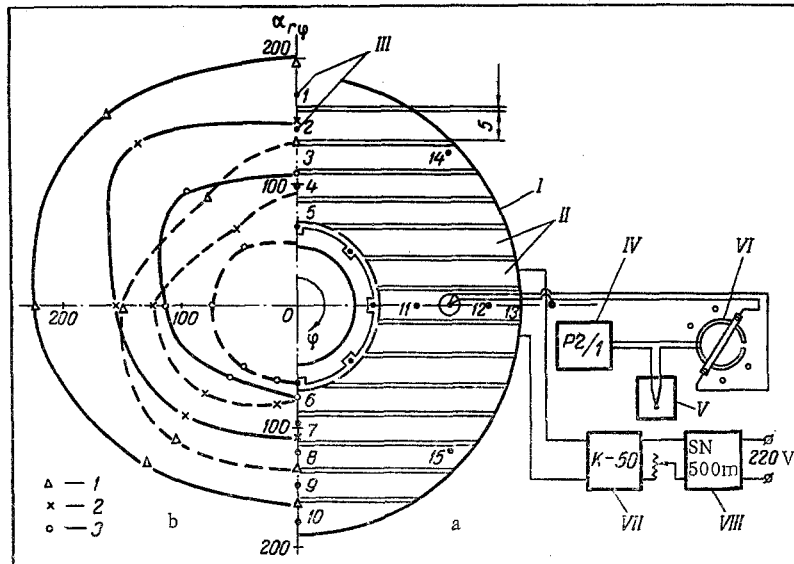

Fig. 1. Electrical calorimeter for the experiment: (a) fin (I), heater ribbon (II), thermocouple junctions 1-15 (III), R 2/1 potentiometer (IV), Dewar flask (V), switch (VI), K-50 instrument panel (VII), SN-500 voltage stabilizer (VIII), and distribution of heat transfer coefficients along the fin surface. (b) $v_{\text{sand}} = 11.0$ (1), 4.6 (2), and 1.2 (3) mm/sec. Solid line is for $r = 27$ mm, dashed line is for $r = 3$ mm, α (W/m² · °C).

transfer coefficients at points 1 and 5 (α_1/α_5) is 1.52, 2.7, 1.25, 1.2, and 1.5 respectively at $\varphi = 0, 45, 90, 135,$ and 180° . It is not possible to fit the relation $\alpha_r/\alpha_p = f(r/r_0)$ into one single equation describing the radial variation of heat transfer intensity: at the front section of the cylinder it is almost exponential, while at the $45^\circ < \varphi < 180^\circ$ region it follows a power law.

It can be seen in Fig. 1b that the manner in which the heat transfer intensity varies with the deflection angle is different for segments adjoining the fin tip and for those adjoining the fin base. Near the fin tip, the heat transfer coefficients increase with the distance from the front section, reaching their maximum and remaining almost constant at that level along the lateral surfaces ($45^\circ < \varphi < 130^\circ$), and then decrease monotonically down to the wake. Near the fin base, the heat transfer coefficients remain almost unchanged at the $0^\circ < \varphi < 70^\circ$ region and begin to increase only at $\varphi > 70^\circ$.

Thus, the lateral fin surfaces are characterized by the maximum heat transfer intensity, while the front and the wake are less effective.

Analogous results are obtained at various velocities of the sand heap (Fig. 1b).

The variation of the heat transfer coefficients around the circumference of the base cylinder is analogous to that shown in [2] for the case of a smooth cylinder without fins, but the intensity of heat transfer is here somewhat lower.

Such a distribution of local heat transfer coefficients over the surface of a finned cylinder is entirely determined by the flow pattern of the sand. The presence of fins does not introduce any qualitative changes: maintained are the stagnation zone at the front and the separation zone at the wake, both characteristic of a transverse flow past a smooth cylinder.

The stagnation zone subtends the upper part of the fin and the separation zone the lower part; only the lateral surfaces are in a continuous stream. The stagnation zone has a shape approaching a pyramid whose width and thickness are maximum at the fin base and both decrease toward the fin tip. The dimensions of the stagnation zone depend on the fin and the cylinder dimensions, on the sand grain size, on the coefficients of internal and external friction, and on the velocity of the sand heap. The maximum height of this zone (at $\varphi = 0^\circ$) always exceeds the height of the fin, the latter being entirely submerged in it along this section. The presence of this stagnation zone, where the material moves slowly, results in a worsening of the heat transfer along the lateral part of the fin. The heat transfer coefficient decreases noticeably

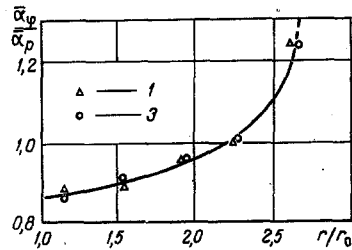

Fig. 2

Fig. 2. Radial variation of mean-over-the-circumference heat transfer coefficients. Symbols are the same as in Fig. 1b.

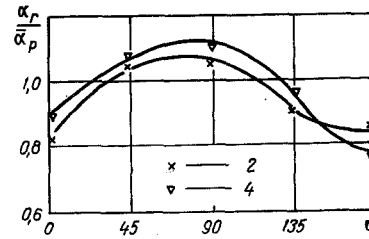

Fig. 3

Fig. 3. Circumferential variation of mean-over-the-radius heat transfer coefficients: $v_s = 4.6$ mm/sec (2) and 7.7 mm/sec (4).

from the tip to the base of the fin at $\varphi = 0$, owing to the increased fin thickness and, therefore, to the increased thermal resistance of the stagnation zone. A still more drastic reduction of the heat transfer intensity in the $20^\circ < \varphi < 70^\circ$ region is explained by the pyramidal shape of the stagnation zone, which leaves the fin tip already outside this zone in a continuous sand stream, while the base remains within it. The heat transfer intensity is high and varies insignificantly along the radius at the lateral surfaces, because the latter are in a continuous sand stream. In this region the maximum heat transfer intensity is observed also at the fin tip, where the time of contact between the sand heap and the heated surface is minimum. The heat transfer at the fin base in the wake zone is affected adversely by the separation of the heap from the cylinder, while the heat transfer intensity at the fin tip is reduced by the longer contact time. The variation of heat transfer intensity around the circumference of the base cylinder is due to the same causes as in the case of a smooth cylinder [2].

An analysis has shown that increasing the velocity of the moving sand makes the heat transfer intensity increase about equally over the entire fin surface. The only exception here is the front part of the fin at the base, where the presence of the stagnation zone reduces somewhat the rate of change of the heat transfer coefficients.

Narrowing the fin spacing within the range under consideration produces a worsening of the heat transfer over the entire fin and cylinder surface, especially in the lateral and in the wake region, which indicates that the stagnation and the separation zone have been thus widened. At the same time, the distribution of local heat transfer coefficients described earlier remains unchanged in character.

The degree of radial and circumferential nonuniformity has been determined on the basis of available data.

In Figure 2 we show, in relative coordinates, the radial variation of heat transfer coefficients around the circumference. The data obtained at various sand velocities fall on a single curve which indicates a rising heat transfer intensity toward the fin tip and which, within a probable error of $\pm 5\%$, can be described by the relation:

$$\frac{\alpha_\varphi}{\alpha_p} = 1.1 (r/r_0)^{0.38}. \quad (1)$$

Thus, the radial nonuniformity within the studied range does not depend on the velocity. For a fin whose height is 30 mm the ratio of mean-over-the-circumference heat transfer coefficients at the tip and at the base (α_1/α_5) is equal to 1.5. The maximum deviations from the mean heat transfer coefficient for the entire fin are -13% and $+30\%$.

Reducing the fin height, with all other conditions unchanged, results in less radial nonuniformity. The circumferential nonuniformity is depicted in Figure 3, where the mean-over-the-radius heat transfer coefficient is shown as a function of the deflection angle. The nonmonotonic variation in heat transfer intensity, with a maximum at the lateral surfaces, is due to the pattern of variation of local parameter values which has been described earlier. The maximum deviations from the overall mean value are as much as -20% and $+15\%$, while the ratio of maximum (at $\varphi = 90^\circ$) to minimum (at $\varphi = 0^\circ$) heat transfer coefficient is 1.44 here. The sand velocity does not seem to affect the circumferential nonuniformity in any significant way.

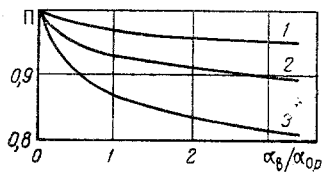

Fig. 4. Correction factor as a function of radial non-uniformity: $mh = 0.5$ (1), 1.0 (2), and 1.5 (3).

At $mh = \text{idem}$, the correction factor differs from unity more as the radial nonuniformity increases.

With a constant nonuniformity according to Eq. (1), the correction factor decreases as the argument (mh) increases. At $\alpha/\alpha_0 = 1.5$ and $mh < 0.5$ the correction factor may be assumed equal to unity, while at $mh > 0.5$ the recommended formula is

$$\Pi = 0.97 - 0.1(mh - 0.5). \quad (2)$$

As the height of annular fins is decreased, the radial nonuniformity will decrease and the correction factor will approach unity. For fins of optimum height (5-10 mm) the correction factor may, within an accuracy adequate for practical purposes, be taken as unity.

It ought to be noted that these conclusions are valid for the case where the effect of circumferential nonuniformity is negligibly small and that these conclusions are, therefore, tentative.

The results can be verified either by analytically solving the equation of heat conduction, with the actual laws of heat transfer variation along two coordinates taken into account, or by experiment (using, for instance, the method of electro-thermal analogy). In the latter case, there appears the possibility of taking into account the variation of fin base temperature as a function of the deflection angle – a result of nonuniform exposure to the sand stream.

The data on local heat transfer have been useful also in comparing the heat transfer intensity at the components of a finned cylinder: at the base cylinder and at the fin. In all cases the mean heat transfer intensity at the fin is higher than at the base cylinder and the difference depends on the fin spacing as well as on the sand velocity. Reducing the spacing between fins worsens the heat transfer at the fins to a lesser degree than at the base cylinder. Thus, with a 3.2 mm/sec sand velocity and a 7 mm fin spacing the heat transfer intensity at the fins is 11% higher than at the base cylinder, while with a 10 mm spacing it is 20% higher. The sand velocity affects the heat transfer at the fins and at the base cylinder much more significantly. When the same velocity becomes 11.5 mm/sec, accordingly, the difference between the heat transfer intensities with the fins spaced as before (7 and 10 mm) increases to 26% and 33% respectively.

It is worthwhile to compare a finned cylinder (diameter 33.5 mm, $h = 30$ mm) with a smooth cylinder for which data have been obtained. The heat transfer intensity at the finned cylinder components and also the overall mean-weighted heat transfer coefficient are lower than for a smooth cylinder, which means that the given finning geometry does not ensure an actual improvement of the heat transfer and this agrees with the data in [1]. This can be explained, as has been indicated earlier, by the less effective cooling in the sand stream on account of the transverse fins. As has been shown in [1], an increase in α as compared to smooth cylinders is attained by means of fins of small height.

NOTATION

- α_1 is the heat transfer coefficient at a given point, W/m^2 ;
- α_r is the mean-over-the-radius heat transfer coefficient, W/m^2 ;
- $\frac{\alpha}{\varphi}$ is the mean-over-the-circumference heat transfer coefficient, W/m^2 ;
- $\frac{\alpha}{p}$ is the overall mean heat transfer coefficient for a fin, W/m^2 ;
- $\bar{\alpha}$ is the overall mean heat transfer coefficient for the entire finned cylinder, W/m^2 ;
- φ is the deflection angle;
- Π is the correction factor;
- v_s is the sand velocity, mm/sec.

LITERATURE CITED

1. V. A. Kalender'yan and V. V. Kornaraki, *Inzh. Fiz. Zh.*, 18, No. 1, (1970).
2. V. A. Kalender'yan, V. V. Kornaraki, and A. P. Markyavichus, *Teploenergetika*, No. 11 (1968).
3. V. K. Migai, *Inzh. Fiz. Zh.*, 6, No. 3, (1963).
4. G. J. Meles, *Nuclear Energy*, Pergamon Press Ltd., London (1957), Vol. 5, pp. 285-300.